

Determining Fault's Type and Accurate Location in Distribution Systems with DG Using MLP Neural Networks

S.A.M. Javadian, *Student Member, IEEE**, A.M. Nasrabadi**,
M.-R. Haghifam, *Senior Member, IEEE****, and J. Rezvantalab, *Student Member, IEEE ***

* Islamic Azad University-Islamshahr Branch, Islamshahr, (Iran)

** Engineering Faculty, Shahed University, Tehran, (Iran)

*** Tarbiat Modares University, Tehran, (Iran)

Abstract--Finding and designing new methods for determining type and exact location of faults in power system has been a major subject for power system protection engineers in recent years. Fault locating in transmission networks is not very hard and complicated due to low impedance of faults. This job is usually done by distance relays. But, in distribution networks, because of high impedance of fault and its vast variety and also simplicity of protective devices, determining the exact location of faults is very complicated. On the other hand, penetration of distribution generation into distribution networks reinforces the necessity of designing new protection systems for these networks. One of the main capabilities that can improve the efficiency of new protection relays in distribution systems is exact fault locating. In this paper, a new approach for determining the exact fault type and location in distribution systems including distributed generation using MLP neural networks is presented. In the suggested method, after determining the fault type, by normalizing the fault current of the main source, the corresponding trained neural network has been activated and the exact location of occurred fault has been derived. The presented method has been implemented on a sample distribution network, simulated by DigSILENT Power Factory 13.2, and its performance has been tested. The simulation results show high performance and accuracy of the method and substantiate that it can be used in modern heuristic protection schemes in distribution systems.

Index Terms-- Distributed Generation, Distribution System, Fault Location, Neural Network

I. INTRODUCTION

One of the important threats for distribution network equipments which has been existed incessantly is occurrence of short circuit fault. Fighting to this danger and protect the system against this phenomena has been a major subject for power engineers for many years. Protection devices and algorithms in power system are the results of challenges to solve this problem and have been developed throughout the time. Recently, using of digital relays in power system protection causes capabilities of protection algorithms and schemes to be increasingly developed [1],[2]. Fault locating in power systems has been a major subject for power and

protection engineers in recent years. In distribution systems, due to large variations of fault impedance, fault location problem has more importance and is more difficult to solve than transmission and generation systems [3]. Furthermore, because of the low cost and significance of distribution network's equipments, it is not economically admissible in this case to design advanced protection schemes for these networks. On the other hand, the reliability of these networks can be greatly increased if the exact location of fault is determined using modified protection systems [1], [2].

Presence of distribution generation and applying renewable energies in distribution networks has been one of the other noticeable subjects for electrical engineers in recent years. DGs are small generation units with lower operational capacity in comparison with large power plants, which use clean and environmentally compatible energy resources to produce electricity. Due to small generation capacity, it is not economical to transfer their energy productions through the power transmission lines. So, DGs are generally connected to distribution systems [4], [5].

Presence of DGs in distribution systems has changed their simple and conventional radial configuration and results in more complexity of their operation, control and protection. Consequently, determining the accurate location of probable faults will be more important in distribution systems including DG [6], [7].

Due to low fault impedance, it is not so intricate to find the fault location in HV transmission lines and is simply done by distance relays. On the contrary, we encounter various and relatively large impedances for faults in distribution systems which are extended in residential, urban and rural regions. With high amount of impedance and its extensive variations in distribution system, classic methods will not be appropriate to specify the fault location [8], [9].

Optimization algorithms and artificial intelligence such as neural network, genetic algorithm, game theory, fuzzy logic, ant colony and simulated annealing have been widely used to solve optimization problems in engineering, so that simplicity and high speed in finding the solution are the results of employing these algorithms. Artificial neural network is one of the powerful methods to solve engineering problems such as classification and function approximation. High capability of neural

This work was supported by Islamic Azad University-Islamshahr Branch.

networks as well as their simplicity results in increasing their usage for solving such problems [10].

In this paper, a novel technique to identify the type and accurate location of short circuit in distribution systems including DG is presented considering fault impedance using artificial neural networks. After introducing the MLP neural networks which are used in this study, the proposed method has been described in detail and finally, in order to illustrate the effectiveness of the suggested approach, the method is applied to a sample distribution network and the results are presented and discussed.

II. MLP NEURAL NETWORKS

Multilayer Perceptrons are feed forward neural networks which consist of several layers of neurons with one layer as output layer and other ones as hidden layers. The number of neurons of output and hidden layers and their transfer functions are related to how the problem is defined. Usually, in technical and engineering problems, MLP neural network with one output and one hidden layer is used. In this kind of problems, linear and Sigmoid transfer functions are used for output and hidden layers respectively. A graphical representation of two-layer MLP which contains 4 inputs, 3 outputs and 9 neurons in hidden layer is shown in Fig. 1. This network has the capability of classifying the inputs to 3 distinct classes with 4 characteristics.

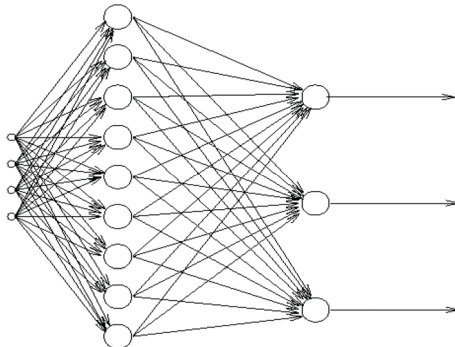

Fig. 1. General configuration of a 2-layer MLP

The block-diagram of a 3-layer Perceptron network is depicted in Fig. 2. As shown in the figure, each layer has one weighting and one bias vector. Multiplying of weighting vector and input vectors is added to bias vector and the result will be the input of transfer function. The output of the transfer function is the input of the next layer. In Fig. 2, R is the numbers of inputs and S1, S2 & S3 are the number of first, second and third layers' neurons respectively.

MLP neural networks train with the standard back propagation algorithm. The back propagation can be described briefly by Fig. 3 and equation (1). In order to train the network and change the weights of neurons, in each iteration, the output of all neurons is calculated in forward path and the weights of neurons are changed in backward path using (1).

In back propagation, the gradient vector of the error surface is calculated. This vector points along the line of steepest descent from the current point, so we know that

if we move along it a "short" distance, we will decrease the error. A sequence of such moves (slowing as we near the bottom) will eventually find a minimum of some sort. The difficult part is to decide how large the steps should be.

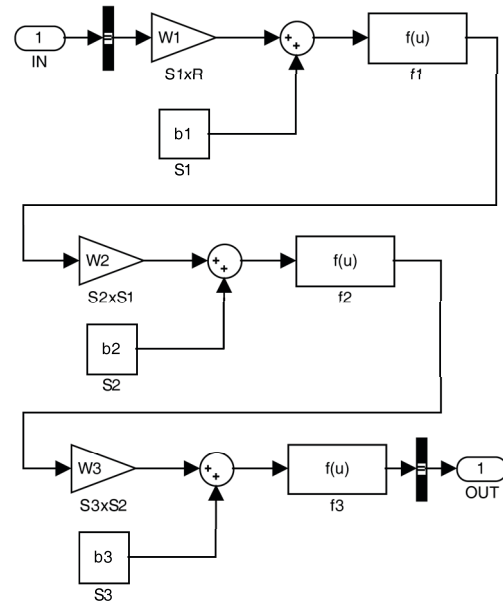

Fig. 2. The block-diagram of a 3-layer Perceptron

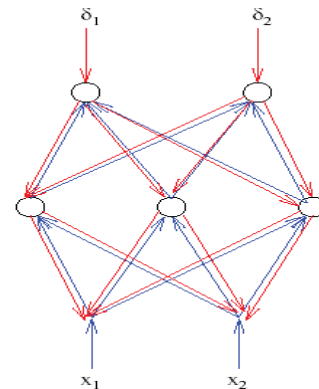

Fig. 3. Standard back propagation training method

$$\begin{pmatrix} \text{Weight} \\ \text{correction} \\ \Delta w_{ji}(n) \end{pmatrix} = \begin{pmatrix} \text{learning} \\ \text{parameter} \\ \eta \end{pmatrix} \cdot \begin{pmatrix} \text{local} \\ \text{gradient} \\ \delta_j(n) \end{pmatrix} \cdot \begin{pmatrix} \text{input signal} \\ \text{to neuron } j \\ y_i(n) \end{pmatrix} \quad (1)$$

Large steps may converge more quickly, but may also overstep the solution or (if the error surface is very eccentric) go off in the wrong direction. A classic example of this in neural network training is where the algorithm progresses very slowly along a steep, narrow, valley, bouncing from one side across to the other. In contrast, very small steps may go in the correct direction, but they also require a large number of iterations. In practice, the step size is proportional to the slope (so that the algorithm settles down in a minimum) and to a special constant: the learning rate. The correct setting for the learning rate is application-dependent, and is typically chosen by experiment; it may also be time-varying, getting smaller as the algorithm progresses.

The algorithm is also usually modified by inclusion of a momentum term: this encourages movement in a fixed direction, so that if several steps are taken in the same direction, the algorithm "picks up speed", which gives it the ability to (sometimes) escape local minimum, and also to move rapidly over flat spots and plateaus.

The algorithm therefore progresses iteratively, through a number of epochs. On each epoch, the training cases are each submitted in turn to the network, and target and actual outputs compared and the error calculated. This error, together with the error surface gradient, is used to adjust the weights, and then the process repeats. The initial network configuration is random, and training stops when a given number of epochs elapses, or when the error reaches an acceptable level, or when the error stops improving (you can select which of these stopping conditions to use).

Back propagation algorithm progresses very slowly. So, because of the great amount of calculations in MLP networks and low convergence speed of the back propagation algorithm, several methods have been proposed to increase its convergence speed. Some of these methods are as follows:

- Gradient decent;
- Gradient decent with momentum;
- Gradient descent with momentum & adaptive learning rate;
- Gradient descent with adaptive learning rate;
- Levenberg-Marquardt;
- Quasi-Newton;
- Conjugate gradient;

III. PROPOSED METHOD FOR DETERMINING THE TYPE AND LOCATION OF FAULT

It is assumed in the proposed method, that all 3 phase current of DGs of the network and the sub-transmission substation are accessible simultaneously and continuously. Regarding to improved and high technology of DGs, distribution automation systems and instruction of the connection of the DGs to distribution network (IEEE-1547 standard), measuring of output current of DG resources and their accessibility are some primary obligations of connection of DGs to these systems. So, taking the assumption of accessibility and usage of output current of DGs and sub-transmission substation will not impose any additional charge to design the protection system. The proposed method in this study consists of two parts which are recognizing fault type and determining fault location. These two parts are described in the following sections.

A. Recognizing the fault type

In order to determine the fault type, only the 3 phase current of the main source is used. At this point, there is no need to ANN and it can be determined with normalizing 3 phase output current of feeding substation. To normalize the mentioned currents, the following equation is used:

$$I_{normal} = \frac{I}{I_{max}} \quad (2)$$

Where:

I: phase current

I_{max}: maximum phase current

Fault type can be determined using (2) and table I.

TABLE I
NORMALIZED CURRENT VECTOR OF THE MAIN SOURCE FOR DIFFERENT FAULT TYPES

Fault Type		I _a	I _b	I _c
1-phase	Ag	1	0	0
	Bg	0	1	0
	Cg	0	0	1
2-phase	AB	1	-1	0
	AC	1	0	-1
	BC	0	1	-1
2-phase to ground	ABg	1	1	0
	ACg	1	0	1
	BCg	0	1	1
3-phase	ABC	1	1	1

B. Determining fault location

After recognizing the fault type, its location should be determined. In this paper, MLP neural network is used for specifying exact location of the fault. The outline of the proposed method is shown in Fig. 4.

After recognizing fault type by its corresponded unit, the trained neural network of this kind of fault is activated and receives the input data which has been prepared by the input data preparation program. The output of the neural network will be the fault distance from all DGs and the main source.

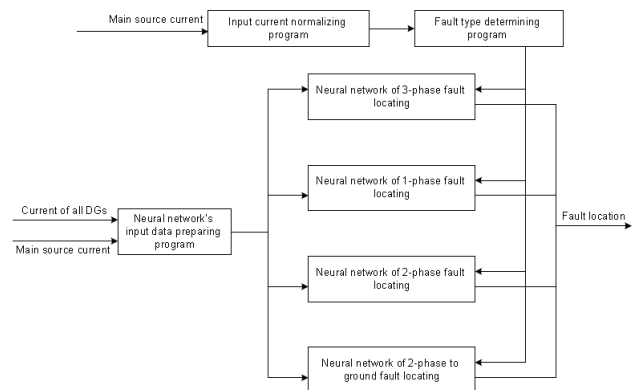

Fig. 4. The outline of the proposed method

As mentioned previously, the major problem of fault locating in distribution networks is fault impedance. For the purpose of minimizing the effect of fault impedance to the output of neural network, appropriate characteristics have to be defined for neural network. Proportional relationship between injected fault current of DGs and feeding substations to each other is taken as the input of neural network in this study.

Injected fault current of each DG can be calculated using (3).

$$I_f = \frac{V}{Z_{th}} \quad (3)$$

Where V is power supply terminal voltage and Z_{th} is the equivalent Thevni impedance of the network. For instance, in the network depicted in Fig. 5, in the case of zero-resistance short circuit in A, equivalent impedance of DG and network is:

$$Z_{DG} = Z_{34} + Z_{3a} \quad (4)$$

$$Z_s = Z_{12} + Z_{2a} \quad (5)$$

Where:

Z_{12} impedance of transmission line between bus 1 and bus 2;

Z_{34} impedance of transmission line between bus 3 and bus 4;

Z_{3a} impedance of the part of the transmission line between bus 3 and point A (fault point);

Z_{2a} impedance of the part of the transmission line between bus 2 and point A (fault point);

In this network the proportion of short circuit current of the network to short circuit current of the DG is

$$\frac{I_S}{I_{DG}} = \frac{Z_{34} + Z_{3a}}{Z_{12} + Z_{2a}} \quad (6)$$

Assuming nonzero-impedance short circuit at point A, the mentioned relation is:

$$\frac{I_S}{I_{DG}} \approx \frac{Z_{34} + Z_{3a} + Z_f}{Z_{12} + Z_{2a} + Z_f} \quad (7)$$

Which is approximately the same as (6). So, using this proportion, i.e. the relation of injected fault current of various resources as the input of the NN, the impact of the fault impedance will decrease to its lowest amount. It can be observed that this method is applicable on distribution networks which include DG. This means the proposed method is only worthwhile for using in those networks and cannot be applied for fault location in conventional distribution systems.

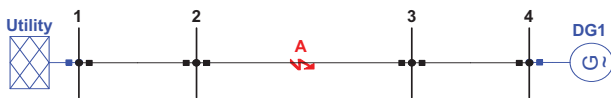

Fig. 5. A simple distribution network with one DG

Furthermore, it is important to be mentioned that by increasing the number of DGs connected to distribution system, the accuracy of fault locating of neural network will be improved due to growth of number of its inputs. For example, in the case of one DG in the network only one input can be used for training the neural network while in the case of n DG resources connected to the network, the number of inputs of neural network is:

$$N = \begin{pmatrix} n \\ 2 \end{pmatrix} \quad (8)$$

Where n is the number of suppliers of fault current (one the network and $n-1$ DG resources). The number of outputs of neural network is n which is equal to the number of fault current suppliers and each output uniquely determines the distance of the fault from its power supply. So, the structure of neural network used in this paper is graphically shown in Fig. 6.

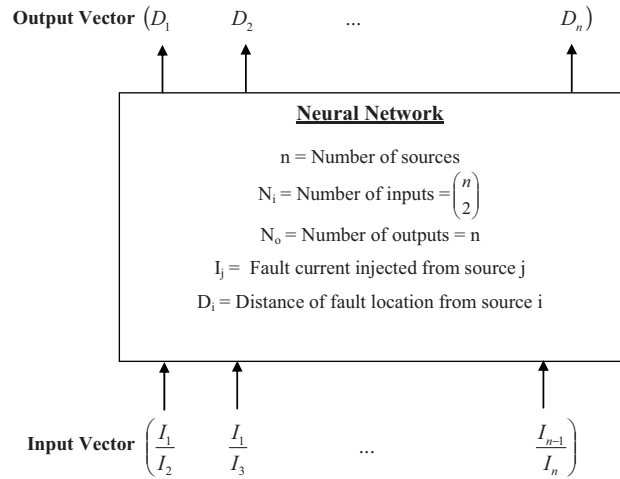

Fig. 6. The structure of neural network

Only one hidden layer is used for the purpose of constructing the neural network, while the neurons number is related to the modifying conditions and cannot be specified precisely. It has to be mentioned here that in a particular problem, the number of neurons in the hidden layer can be determined with try-and-error method. The number of output layer neurons is equal to the number of outputs. Linear type and hyperbolic tangent type transfer function is considered for output and hidden layer neurons, respectively, and Levenberg-Marquardt algorithm for neural network training method.

IV. SIMULATIONS

In this paper for modeling and simulation of sample distribution network and extracting necessary data for training of neural network, DIGSILENT Power Factory 13.2 is used and simulation of neural network is done in MATLAB as well.

A 16-bus, 20 kV distribution network with three 3MVA diesel generators is considered as a test system for simulation. Single line diagram of this network is illustrated in Fig. 7. The technical data of the equipments are given in the Appendix.

In order to prepare the required data for training the neural network, all types of faults in the system in each 100 meter and with 0, 50, 100, 150 ohm fault impedance is simulated and the output current of all power supplies are exploited. Training results of all neural networks are shown in Figs. 8 to 11. Neural network structures for

each fault type as well as their training error are tabulated in table II.

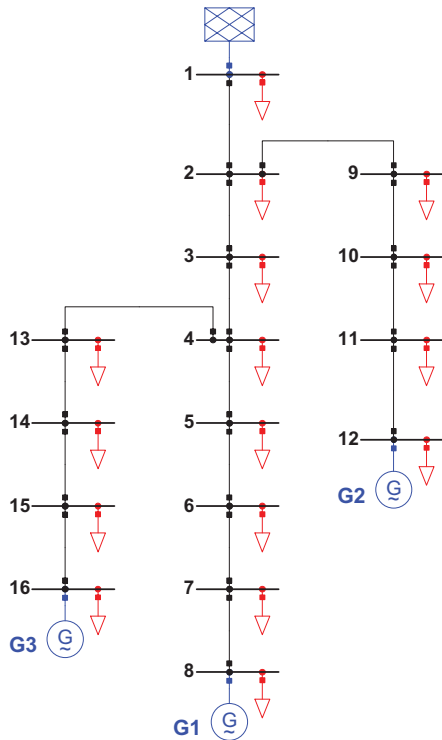

Fig. 7. The studied distribution network

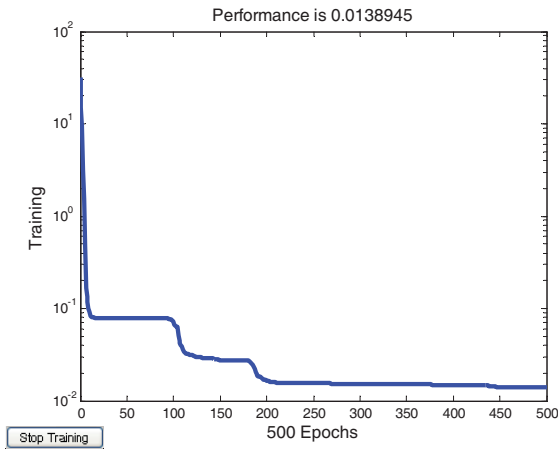

Fig. 8. Training result of neural network for 3-phase faults

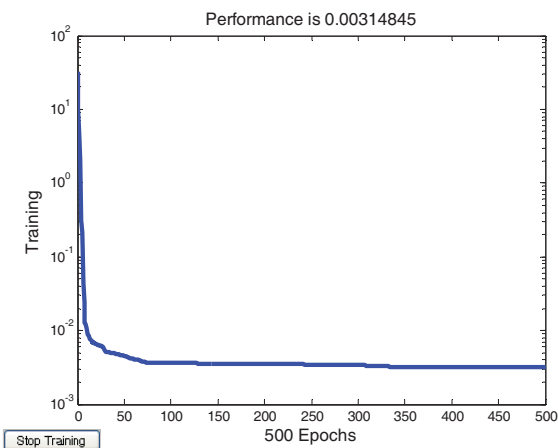

Fig. 9. Training result of neural network for 1-phase faults

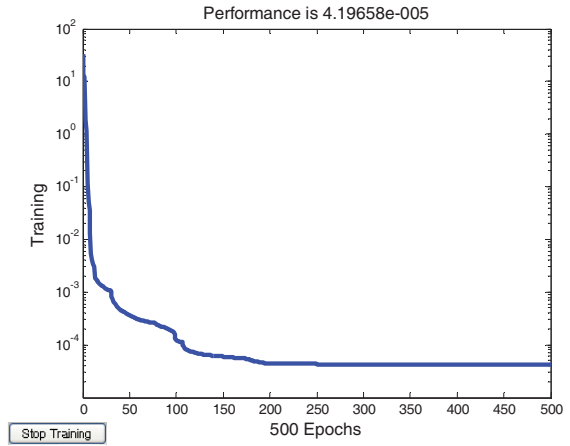

Fig. 10. Training result of neural network for 2-phase faults

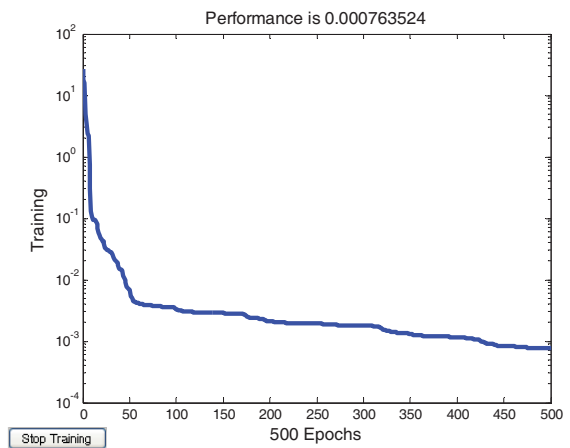

Fig. 11. Training result of neural network for 2-phase to ground faults

TABLE II
STRUCTURE AND ERROR OF TRAINED NEURAL NETWORKS

Fault Type	NN Structure	MSE
3-phase	[6 6 4]	0.0138945
1-phase	[6 5 4]	0.00314845
2-phase	[6 7 4]	0.0000419658
2-phase to ground	[6 7 4]	0.000763524

According to the results, the highest error of trained neural networks is 20 meters. Regarding to 1km length of distribution lines in studied network and knowing that recognizing the faulted line is the final goal of protection systems in distribution networks, the deviation in proposed method is passable and quite satisfying and can be used for designing the intelligent protection systems for distributed networks in presence of DGs.

V. CONCLUSIONS

A new method using MLP neural network to determine the type and location of fault in distributed networks is presented in this paper. In the method, to reduce the impact of fault impedance to determine the fault location, proportion of injected power supplies current is taken into account and used as the input of

neural network. Having normalized the fault current injected from feeding substation, the fault type is recognized and afterwards the trained neural network related to this fault is used to specify the distance of the fault from each power supplies. The proposed method was implemented on a sample distribution system simulated in DIGSILENT Power Factory and the required data for training the neural networks is extracted. Simulation results demonstrate the power, effectiveness and great accuracy of the method and confirm its acceptable capability to be used for designing the intelligent protection schemes in modern electrical power distribution systems.

APPENDIX

All the distribution conductors used in simulation are HYENA with 1 km length and technical information mentioned in table III.

TABLE III
TECHNICAL DATA OF DISTRIBUTION LINES

Conductor Name	Type	A
HYENA	ACSR	126 mm ²
Technical Data	R (Ω)	0.303
	X (Ω)	0.3383
	R ₀ (Ω)	0.4509
	X ₀ (Ω)	1.5866
	I _n (A)	250

Technical data of DGs are presented in tables IV.

TABLE IV
TECHNICAL DATA OF DGs

Machine Type	IEC 909	Salient Pole Series 1	
Voltage (kV)	20	X'd (pu)	0.256
P _n (MW)	3	X''d (pu)	0.168
PF _n	0.8	X ₀ (pu)	0.1
Connection	YN	X ₂ (pu)	0.2
X _d (pu)	1.5	R ₀ =R ₂ (pu)	0
X _q (pu)	0.75	R _{str} (pu)	0.504

REFERENCES

- Javadian, S. A. M.; Haghifam, M. R.: *Protection of Distribution Networks in Presence of DG Using Distribution Automation System Capabilities*, Proc. 2008 IEEE Power Engineering Society General Meeting, 20-24 July 2008, pp.1-6.
- Javadian, S. A. M.; Haghifam, M. R.: *Implementation of a new protection scheme on a real distribution system in presence of DG*, Proc. POWERCON 2008 and 2008 IEEE Power India Conference, 12-15 October 2008, New Delhi, India, pp.1-7.
- Rezaei, N.; Haghifam, M. R.: *Protection scheme for a distribution system with distributed generation using neural networks*, International Journal of Electrical Power & Energy Systems, Volume 30, Issue 4, May 2008, pp. 235-241.
- Barker, P. P. ; de Mello, R. W. : *Determining the impact of distributed generation on power systems: part1-radial distribution systems*, IEEE Trans. Power Delivery, vol. 15, pp. 486–493, Apr. 2000.
- Dugan, R. C.; McDermott, T. E.: *Operating conflicts for Distributed Generation interconnected with Utility Distribution Systems*, IEEE Industry Applications Magazines, 19-25, Mar/Apr. 2002.
- Javadian, S.A.M.; Haghifam, M.R.: *Designing a New Protection System for Distribution Networks including DG*, The 9th IET International conf. on Developments in Power System Protection, 17-20 March 2008, pp. 675-680.
- Farzanehratif; Javadian, S.A.M.; Bathaee, S.M.T.; Haghifam, M.R.: *Maintaining the Recloser-Fuse Coordination in Distribution Systems in Presence of DG by Determining DG's Size*, The 9th IET International conf. on Developments in Power System Protection, 17-20 March 2008, pp. 124-129.
- Jiang, J.A; Liu, Y.H; Liu, C.W; Yang, J.Z; Too, T.M: *An adaptive fault locator system for transmission lines*, IEEE PES summer meeting, vol. 2, 1999. pp. 930–936.
- Meshal,A.; Al-shaher,A.; Manar, M.; Sabry,B.; Ahmad, S.; S. Saleh: *Fault location in multi-ring distribution network using artificial neural network*, Electric Power Systems Research, vol. 64, 2003 pp. 87–92.
- Ehsan, M.; Soroudi,A.: *An Introduction to Heuristic Search Algorithms for Optimization of Engineering Problems*, International Conference on Genetic and Evolutionary Methods, USA, June 25-28, 2007.
- Haykin, S.: *Neural Networks a comprehensive foundation*, Second edition, Prentice-Hall, Inc. 1999.
- K. Y. Lee, K. Y.; El-Sharkawi, M. A.: *Modern Heuristic Optimization Techniques, Theory and Applications to Power Systems*, John Wiley & Sons Inc., 2008.
- Baran, M. E.; El - Markaby, I.: *Fault analysis on distribution feeders with distributed generators*, IEEE Transactions on Power Systems, vol. 20 (4), pp. 1757-1764, 2005.
- Haghifam, M. R.; Falaghi, H.; Malik, O. P.: *Risk-based distributed generation placement*, IET Generation Transmission Distribution, 2008, 2, (2), pp. 252-260.
- Hadjsaid, N.; Canard, J.; Dumas, F.: *Dispersed generation impact on distribution networks*, IEEE Comput. Appl. Power, vol. 12, pp. 22–28, Apr. 1999.
- Comassetto, L.; Bernardon, D. P.; Canha, L. N.; Abaide, A. R.: *Software for automatic coordination of protection devices in distribution system*, IEEE Transaction on Power Delivery, Vol. 23, NO. 4, October 2008, pp. 2241-2246.
- IEEE Standard for Interconnecting Distributed Resources with Electric Power Systems*, IEEE Std. 1547, July 2003.
- IEEE Standard Conformance Test Procedures for Equipment Interconnecting Distributed Resources with Electric Power Systems*, IEEE Std. 1547.1, June 2005.
- IEEE Guide for Monitoring, Information Exchange, and Control of Distributed Resources Interconnected with Electric Power Systems*, IEEE Std. 1547.3, Nov. 2007.
- Javadian, S. A. M.; Haghifam, M. R.; Barazandeh, P.: *An Adaptive Over-current Protection Scheme for MV Distribution Networks Including DG*, Proc. ISIE08 - IEEE International Symposium on Industrial Electronics, 30th June to 2nd July 2008, Cambridge, UK, pp. 2520-2525.
- Tamizkar, R.; Javadian, S. A. M.; Haghifam, M.-R.: *Distribution System Reconfiguration for Optimal Operation of Distributed Generation*, International Conference on Clean Electrical Power (ICCEP2009), June 9th – 11th, 2009, Capri, Italy (Accepted).